

Digital Cabinets

Thawing Cabinet, 1 Door, 670L, 10 Positions, 120V/60Hz R290

ITEM # _____

MODEL # _____

NAME # _____

SIS # _____

AIA # _____

725449 (TC671DUCB2)

 1-DOOR THAWING
 CABINET 670L, 10
 POSITIONS, 120V/60Hz
 R290 - US

Short Form Specification

Item No.

Full door thawing cabinet mainly constructed in A304 stainless steel for everlasting operation in all working environments. Fully pressed bottom plate and rounded corners; it is supplied with 10 AISI 304 grids 2/1 and the rack support can be removed without tools.

Control panel indicating the real temperature evolution of the cabinet during the preservation process. The electronic control switches automatically from thawing into preservation to avoid bacteria proliferation. It is fully customizable in time, temperatures and thaw/ preservation split of phases. Up to 7 programs to cope with loads from approx 20kg to 80kg. Fan speed adjustable during thawing cycles.

Built-in refrigeration unit with R290 gas in refrigeration circuit. Meets HACCP requirements. Delivered on wheels. Plug included.

Main Features

- Up to 7 programs to cope with loads from approx 44lb to 176lb.
- Cabinet fitted with up to 3" (75 mm) thickness of cyclopentane insulation for best insulating performance with 100% environmental protection (thermal conductivity: 0,020 W/m*K).
- Powerful fan to ensure a quick and uniform thawing process.
- Fan speed adjustable during thawing cycles.
- Fully HACCP compliant thanks to the temperature control, visualisation and alarm management.
- Fully customizable parameters to suit even the most demanding needs.
- Temperature display shows real temperature evolution allowing for frequent and brief checks during the thawing-preservation process.
- The electronic control switches automatically from thawing into preservation to avoid bacteria proliferation.
- Even airflow ensured by back air conveyor and ensuring consistent results on products to be thawed in a single load.
- 10 AISI 304 grids GN 2/1 supplied as standard to maximise internal space.
- Lockable door with closure latch.
- Cord and plug included.

Construction

- Mainly construction in A304 stainless steel for everlasting operation in all working environment.
- Fully pressed bottom plate and rounded corners for easier cleaning.
- 4 wheels (front ones with brakes) are supplied as standard to ease cleaning operations.
- Developed and produced in ISO 9001 and ISO 14001 certified factory.

Sustainability



- CFC, HCFC, HFC-free insulation.
- CFC and HCFC free, highly ecological refrigerant type: R290 (ecological gas in foam: cyclopentane). Hydrocarbon refrigerant gas R290 for the lowest environmental impact (GWP=3), to reduce green house and ozone depletion effects.

Included Accessories

- 1 of 4 swiveling wheels (2 with brake) PNC 881002
- 10 of 20" x 26" AISI 304 stainless steel grid PNC 881016

Optional Accessories

- 4 swiveling wheels (2 with brake) PNC 881002
- 20" x 26" AISI 304 stainless steel grid PNC 881016
- Kit door with reduced depth and deflector PNC 881220
- EXTERNAL DOOR HANDLE FOR THAWING CABINET PNC 881255

APPROVAL: _____

Front

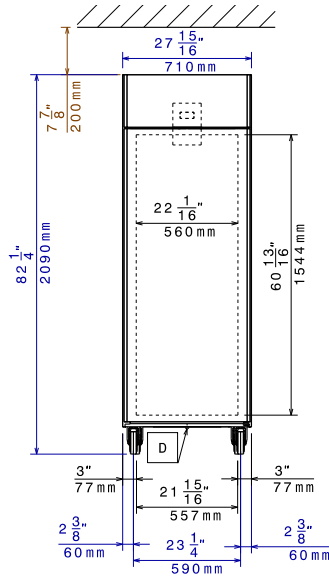

Side

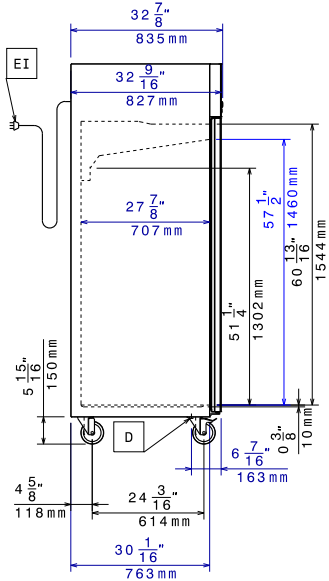

EI = Electrical connection

Top

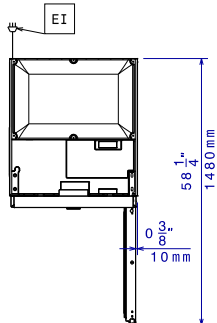

Electric

Supply voltage:	725449 (TC671DUCB2)	115 V/1 ph/60 Hz
Electrical power, max:		1.4 kW
Plug type:		USA NEMA 5-20P

Key Information:

ETL Cert. Model:	VIMTTNUHK
N° of doors:	1
Capacity:	
External dimensions, Width:	27 15/16" (710 mm)
External dimensions, Depth:	32 7/8" (835 mm)
External dimensions, Height:	82 1/4" (2090 mm)
Internal Dimensions (depth):	27 13/16"
Internal Dimensions (height):	57 1/2"
Internal Dimensions (width):	22 1/16"
Shipping height:	86 1/4" (2190 mm)
Shipping weight:	414 lbs (188 kg)
Shipping volume:	68.32 ft ³ (1.93 m ³)
Type of external material:	304 AISI
Type of internal material:	304 AISI
External side panels:	304 AISI
External top panels:	304 AISI
External door material:	304 AISI
Internal panels material:	304 AISI
Approvals	ETL C&US; ETL SANITATION

Refrigeration Data

Control type:	Digital
Operating temperature min.:	ISO 9001 °F
Operating temperature max.:	50 °F

ISO Certificates

ISO Standards:	ISO 9001; ISO 14001; ISO 45001; ISO 50001
----------------	---

Sustainability

Current consumption:	12.3 Amps
Noise level:	54 dBA
Refrigerant type:	R290